



## INFRARED EMITTING DIODE

## PART NO. : CIL-54CC2-T2-2.2

### Features

- I High radiant power and high radiant intensity
- I Suitable for DC and high pulse current operation
- I Standard T- $\phi$ (3mm) package, radiation angle:40°
- I Peak wavelength  $\lambda_p = 940 \text{ nm}$
- I Good spectral matching to si-photodetector

### Package Dimensions Unit: mm

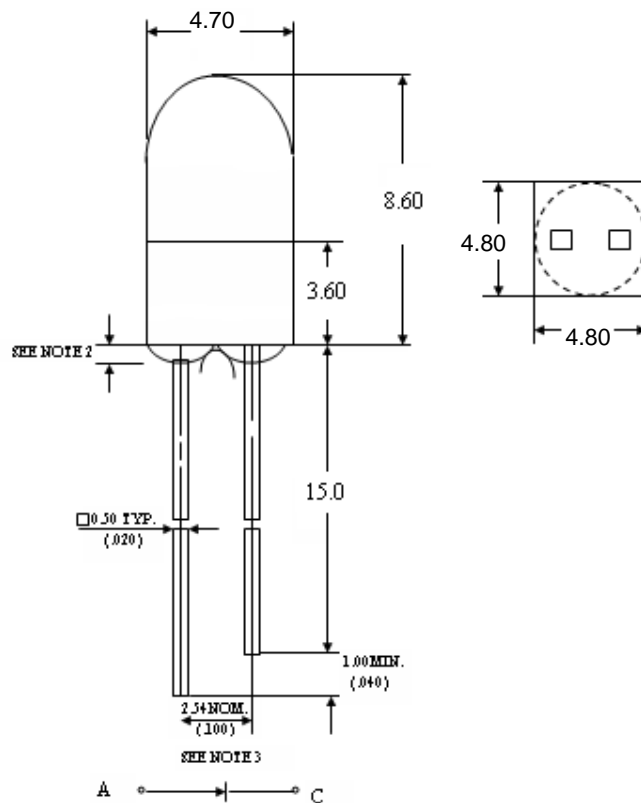

### Note

1. All dimensions are in millimeters
2. Tolerance is  $\pm 0.25 \text{ mm}$  unless otherwise noted.
3. Protruded resin under flange is 1.5 mm max.
4. Lead spacing is measured where the leads emerge from the package.

Lens	Chip Material
Water clear	GaAs /AlGaAs



## INFRARED EMITTING DIODE

## PART NO. : CIL-54CC2-T2-2.2

### Absolute Maximum Ratings at T<sub>A</sub>=25°C

Parameter	Maximum Rating	Unit
Power Dissipation	100	mW
Peak Forward Current (1/10 Duty Cycle, 0.1ms Pulse Width)	0.8	A
Continuous Forward Current	80	mA
Reverse Voltage	5	V
Operating Temperature Range	-40°C to +85°C	
Storage Temperature Range	-40°C to +100°C	
Lead Soldering Temperature(1.6mm From Body)	260°C for 5 seconds	
Lead Soldering Temperature(5mm From Body)	350°C for 3 seconds	

### Optical-Electrical Characteristics at T<sub>A</sub>=25°C

Parameter	Test Conditions	Symbol	Min.	Typ .	Max.	Unit
Radiant Intensity	I <sub>F</sub> =20mA	I <sub>e</sub>	3.5	10	-----	mW/sr
	I <sub>F</sub> =300mA	I <sub>e</sub>	33	110	-----	mW/sr
Forward Voltage	I <sub>F</sub> =50mA	V <sub>F</sub>	-----	1.32	1.45	V
	I <sub>F</sub> =200 mA	V <sub>F</sub>	-----	1.65	2.0	V
Reverse Current	V <sub>R</sub> =5V	I <sub>R</sub>	-----	-----	100	μA
Peak Wavelength	I <sub>F</sub> =20mA	λ <sub>p</sub>	-----	940	-----	nm
Spectral Bandwidth	I <sub>F</sub> =20mA	Δλ	-----	50	-----	nm
View Angle	I <sub>F</sub> =20mA	2θ <sub>1/2</sub>	-----	40	-----	deg .



### Typical Optical-Electrical Characteristic Curves

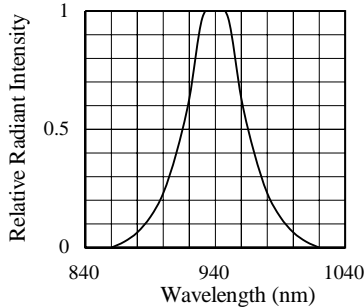

FIG.1 SPECTRAL DISTRIBUTION

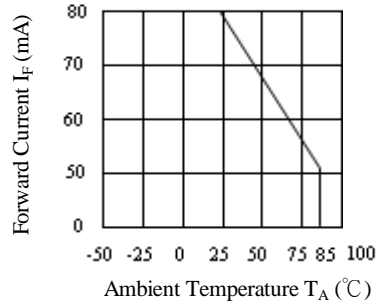

FIG.2 FORWARD CURRENT VS. AMBIENT TEMPERATURE

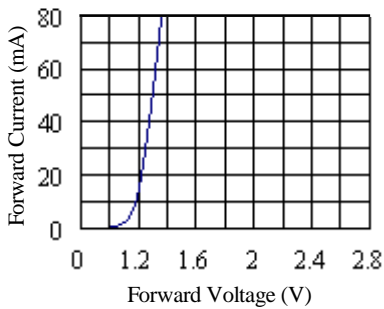

FIG.3 FORWARD CURRENT VS. FORWARD VOLTAGE

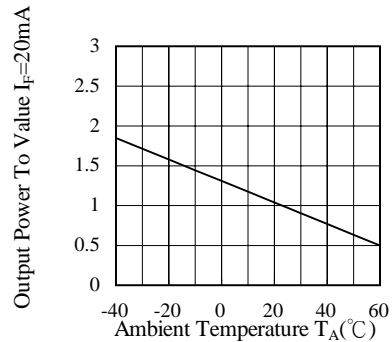

FIG.4 RELATIVE RADIANT INTENSITY VS. AMBIENT TEMPERATURE

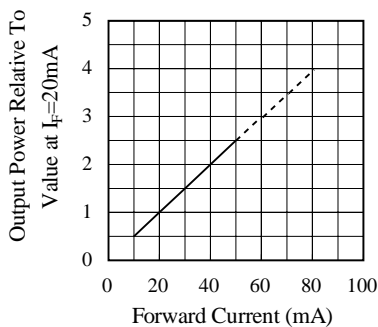

FIG.5 RELATIVE RADIANT INTENSITY VS. FORWARD CURRENT

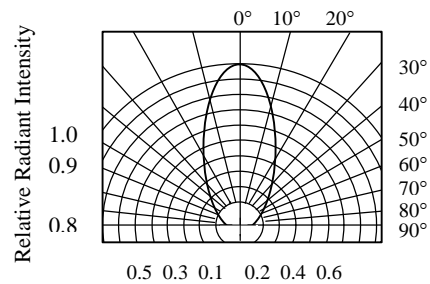

FIG.6 RADIATION DIAGRAM



## **INFRARED EMITTING DIODE**

## **PART NO. : CIL-54CC2-T2-2.2**

### Reliability test items and test conditions

The reliability of products shall be satisfied with items listed below.

Confidence level : 90%

LTPD (group of permitted defect rate): 10%

No.	Item	Test Conditions	Test Hours/ Cycles	Sample Sizes	Ac/Re	Reference Standard
1	REFLOW Soldering	Temp. : 260 ±5	5secs	22PCS	0/1	JEITA ED-4701 300 302
2	Temperature Cycle	H : +100 15min ~ 5 min L : -40 15min	100Cycles	22PCS	0/1	JEITA ED-4701 100 305
3	Thermal Shock	H : +100 5min ~ 10 sec L : -10 5min	100Cycles	22PCS	0/1	MIL-STD-202G
4	High Temperature Storage	Temp. : 100	1000Hrs	22PCS	0/1	JEITA ED-4701 200 201
5	Low Temperature Storage	Temp. : -40	1000Hrs	22PCS	0/1	JEITA ED-4701 200 202
6	DC Operating Life	IF = 50 mA	1000Hrs	22PCS	0/1	Tested with CGX standard
7	High Temperature/ High Humidity	85 /RH85%	1000Hrs	22PCS	0/1	JEITA ED-4701 100 103

Notes : Failure Judgement Criteria : IR U×2 Ie L×0.8 VF U×1.2

U : Upper Specification Limit L : Lower Specification Limit